

# LDM-NH-1212 NEON Light Strip



## LDM-NH-1212



### Key Features

- **Uniform and Soft Lighting:** Professional structural design ensures even luminance with no visible light spots. Durable Silicone
- **Coating:** Anti-yellowing and heat-resistant, suitable for outdoor environments.
- **Robust and Waterproof:** Resistant to corrosion, acid, and alkali, making it ideal for harsh environments with excellent waterproof performance.
- **Highly Flexible:** Offers excellent flexibility, allowing for versatile shaping and customization.

### Application:

- **Architectural Accents:** Highlights features in tight spaces with precision lighting.
- **Indoor/Outdoor Ambiance:** Creates warm, inviting environments in any setting.
- **Custom Lighting:** Perfect for detailed installations requiring high color accuracy.
- **Signage and Displays:** Ideal for backlighting and outlining signs.
- **Pathways and Landscaping:** Durable, waterproof lighting for outdoor use.
- **Accent and Cove Lighting:** Enhances interior aesthetics with warm white light.

Specifications	
Models	LDM-1212
Product Size(mm)	5000*12*12
LED Type	2835
Single Color Temperature*	3000
Lumen/Meter	720-1080
Input Voltage*	24V DC
Current (Amps/meter)	0.42
Min Cuttable Length(mm)	25.45
Max Power Consumption (Watt/m)	12
CRI	> 90
Driver Input	120V AC
Power Factor	0.9
Dimming	Dimmable
Beam Angle	180°
LED Quantity(per meter)	120Pcs
Net Weight(kg)	0.65
Operating Temperature	-20~50 °C
Storage Temperature	-30°C~ +80°C
IP Rate	67
Estimated Life(Hours)	30,000
Certification	cETLus
Warranty	3-year

### Dimensions

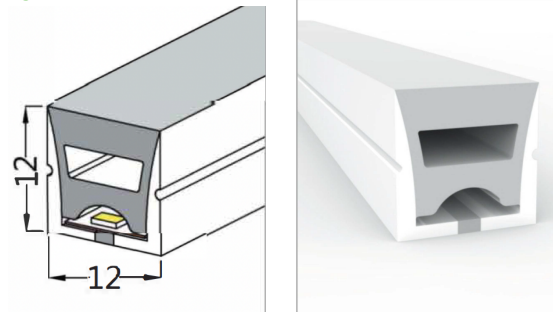

### Installation Instructions - Cutting Method

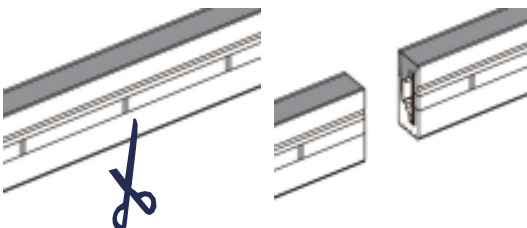

### Linking operation:

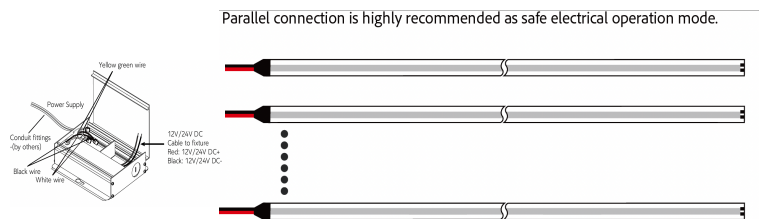

### Ordering Guide

Example: LDM-NH-1212

Series	LED Type	Size	Color Temperature	Size(Meter)	
LDM	LED Strip Light	NH	1212	3000K	5